

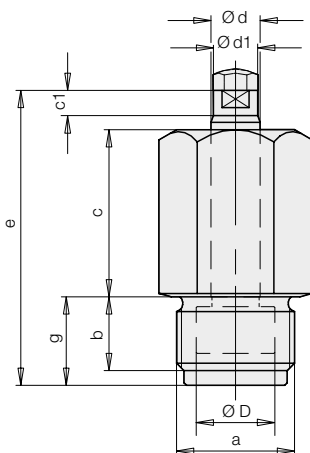

**Threaded-Body Cylinders**

single acting, spring return, with wiper  
max. operating pressure 500 bar



**Porting details at fixture**

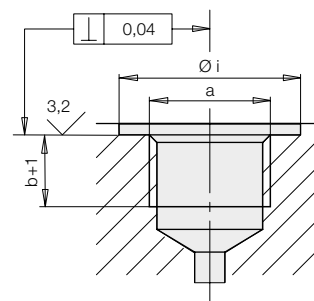

Sealing is attained by a knife edge at cylinder collar, requiring the sealing surface to be square to hole axis and flat.

**Description**

These clamping cylinders may be threaded directly into tapped holes of the fixture. These compact devices can be used to great advantage in fixtures where space is at a premium. Hydraulic fluid is supplied through passages drilled into the fixture body, thus eliminating hydraulic hoses and threaded fittings. The built-in spring returns the piston when hydraulic pressure is released. The internal threads at the piston rod end accept contact bolts. Contact bolts see data sheet G 3.800.

**Material**

Piston material: casehardening steel, hardened  
Cylinder body: free-cutting steel, black oxide

**Important notes**

**Threaded-body cylinders must not be subjected to a load in retracted position.**

Operating conditions, tolerances and other data see data sheet A 0.100.

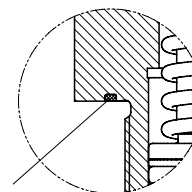
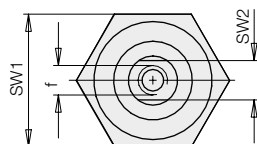

For piston Ø D = 32 mm the knife edge will be replaced by a Kantseal joint

Piston Ø D	[mm]	12	16	25	32
Rod Ø d	[mm]	8	10	16	20
Stroke ± 0.5	[mm]	8	10	10	16
Clamping force at 100 bar	[kN]	1.1	2.0	4.9	8
Clamping force at 500 bar	[kN]	5.6	10.0	24.5	40
Spring return force, min	[N]	32	56	151	183
Oil volume/10 mm stroke	[cm <sup>3</sup> ]	1.13	2.01	4.91	8.04
a	[mm]	M 20x1.5	M 24x1.5	M 36x1.5	M 42x1.5
b	[mm]	12	15	20	25
c	[mm]	25	34	35	40
Ø d1 x c1	[mm]	7,7x4	9,2x4	15x5	19x7,5
e ± 0.5	[mm]	46	58	66	75
f x depth of thread	[mm]	M 5 x 10	M 6 x 12	M 10 x 15	M 12x15
g	[mm]	15	18	23	25
Ø i	[mm]	29	33	49	65
SW 1	[mm]	24	27	41	55
SW 2	[mm]	7	8	13	17
Max. seating torque	[Nm]	90	110	130	200
Weight	[kg]	0.16	0.25	0.65	0.92
<b>Part no.</b>		<b>1450000</b>	<b>1451000</b>	<b>1453000</b>	<b>1454000</b>

**Application example**

